



< timetorelax

Since the company was founded back in the year 2000, the name CASADA has become synonymous with high-quality products in the wellness and fitness sector.

Today, CASADA products are available worldwide. Continuous development, unmistakable design and a strict focus on improving quality of life are just as much characteristic of CASADA products as reliable and top-class quality.

Congratulations!

By purchasing this massage chair you have demonstrated an awareness for your health.

So that you can benefit from the advantages of this device for a long time, we would ask that you read and observe the safety instructions carefully.

We very much hope you enjoy using your personal AlphaSonic II.

Table of Contents

Safety instructions	26
Contraindications.....	27
Equipment Functions.....	28
Remote control.....	29
Quick access remote control.....	29
Starting up.....	34
Specials.....	39
Troubleshooting.....	44
Storage Maintenance.....	44
Specifications.....	44
EU – Declaration of Conformity	45
Warranty conditions	45

Safety instructions



Please read the following instructions carefully before using your massage chair, to ensure that it functions properly and with optimal efficiency. Please retain these operating instructions for further use!

- The massage chair conforms to recognised technical principles and the latest safety regulations.
- The massage chair is equipped with heated sections. Persons who are sensitive to heat should take care when using the product. (ICE 60335-2-32)
- The massage chair does not require maintenance. Any possible repairs may only be carried out by authorised experts.
- Improper use and unauthorised repairs are not permitted for safety reasons and lead to loss of warranty.
- In order to avoid injury please do not stick your fingers between the massage rollers.
- Never touch the mains plug with wet hands.
- Do not allow the massage chair to come into contact with water, high temperatures or direct sunlight.
- Do not use the massage chair in an environment with high humidity levels e.g. in the bathroom.
- Do not use the massage chair in an area with insufficient space or in an area where the ventilation is covered and a supply of fresh air is not guaranteed.
- To avoid the danger of short-circuits, disconnect the massage chair from the power supply if it is not in use for a long period of time.
- Do not use any damaged cables, plugs or loose sockets.
- If cables/plugs are damaged, they must be replaced by the manufacturer, a service representative or by qualified personnel.
- In the case of malfunction, immediately disconnect the product from the mains.
- The company disclaims any liability for damage if the product is in use inappropriately or incorrectly.
- Do not exceed the daily recommended massage duration of 30 minutes in order to avoid excessive strain on the muscles and the nerves.
- To avoid damaging the massage chair, never use pointed or sharp objects.
- In order to reduce the danger of short circuits or fire, it is essential to use only sockets that fit the plug and to ensure that the plug is fully inserted into the socket.
- Disconnect the massage chair from the power supply after use and before cleaning.
- Do not allow children under 14 to clean or maintain the product without supervision.
- If an unexpected power failure occurs during use, immediately set the switch to the OFF position and disconnect the plug in order to avoid damage to the massage chair.
- Do not use the massage chair if the electric cables are wet or damaged.
- Children under the age of 14, people with disabilities and frail people must be supervised at all times when in the vicinity of the massage chair or when using the massage chair.
- Do not use the massage chair immediately after consuming a meal or when under the influence of alcohol.
- Only use the product for the purpose described in the operating instructions.
- Please only use accessories provided by the supplier.
- To prevent damage, please do not stand, sit or bounce on the footrest.
- To avoid damage or injury, do not try to sit on the armrests or backrest.
- Please clean your massage chair regularly and prevent foreign bodies from penetrating the crevices of the massage chair.
- Please do not pull directly on the mains cable.
- When adjusting the position of the footrest or the backrest, please ensure that there are no other objects underneath, in particular no children under the age of 14.
- The product is only intended for domestic use.
- If the flexible power cable becomes damaged, another flexible cable designated for the same purpose must be used or a suitable replacement cable must be purchased from the manufacturer or their service point.

Contraindications

If you are unsure whether you should use the massage chair, consult your doctor by all means.

- Use of the massage chair is prohibited during pregnancy or in the case of one or several of the following complaints: Recent injuries, thrombotic diseases, any kinds of inflammations and swellings, and cancer. If you are undergoing treatment for illnesses or conditions it is recommended that you consult with a doctor before getting a massage.
- Persons with physical, cognitive or mental impairments or persons lacking experience and knowledge should only use this chair under the supervision and guidance of persons responsible for their safety.
- In order to avoid any discomfort or danger when using the massage chair, we would ask the following people to consult a doctor before using the product:
 - Non-ambulant persons
 - Persons receiving medical treatment
 - Patients with back pain and persons with spinal problems / curvature of the spine.
 - Persons with pacemakers
- If you experience pain during the massage, stop using the product immediately.
- If you injure yourself whilst using the chair, seek immediate medical treatment.
- Please do not massage any reddened, swollen or inflamed areas of the skin.
- This massage chair is intended to be used only for home wellness massages and is not a medical massage device. It can therefore not be used as a substitute for specialist medical treatment.
- We recommended that you use the massage chair for 30 minutes on a daily basis. Individual areas of the body should be massaged for a maximum of 15 minutes at a time, as excessive massaging can otherwise be counter-productive.
- This product is not suitable for children under the age of 14.
- Children under the age of 14 must be supervised. Ensure that children do not play with the massage chair.

“BRAINTRONICS” CONTRAINDICATIONS

- Psychoses (e.g. Schizophrenia, bipolar disorder, endogenous depression)
- Personality disorders
- Epilepsy and similar seizure disorders
- Heart conditions
- Diseases of the central nervous system
- Thrombosis
- Endogenous depression
- ADHD (under-active)
- Recent heart attack or stroke
- Mental disability
- Addictions such as to drugs or alcohol or dependency on medication
- Regular intake of psychotropic drugs
- Pregnancy

NOTE: For ethical and legal reasons, braintronics should not be used on children and young people without the explicit permission of the legal representatives. Persons for whom meditation may conflict with religious beliefs should refrain from using the product.

Equipment | Functions

1. Pillow
2. Shoulder airbag
3. Quick access remote control
4. Forearm airbag
5. Seat cushion
6. Calves airbag
7. Foot airbag
8. Footrest
9. Backrest cushion
10. Decorative trim
11. Armrest
12. Side cover

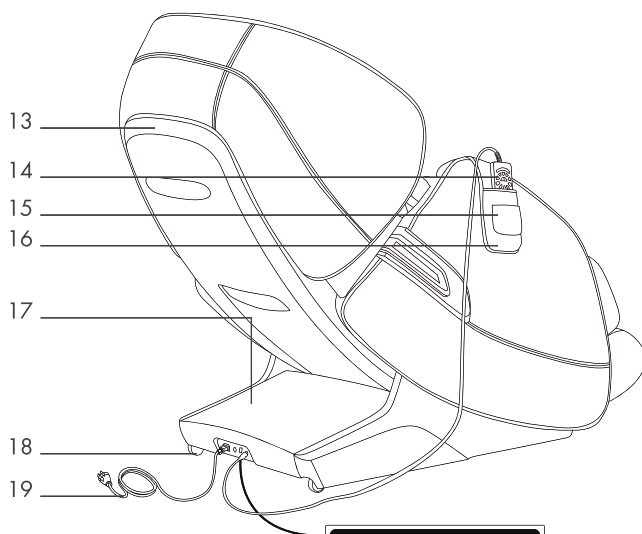
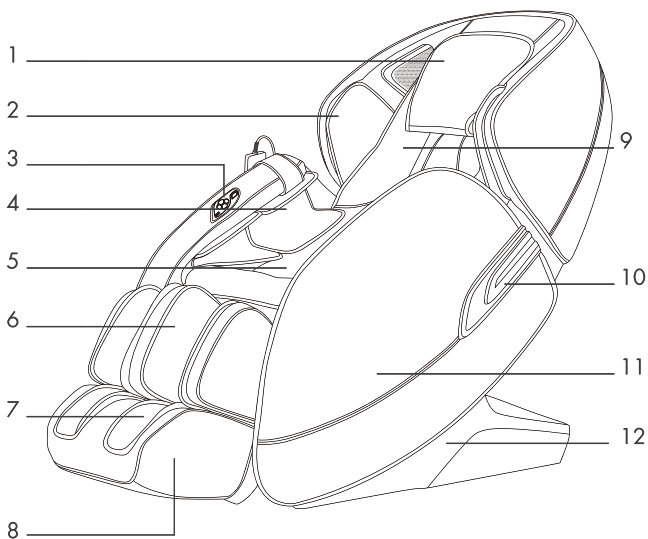

13. Back cover
14. Remote control
15. Pocket for mobile phone
16. Pocket for remote control
17. Safety cover
18. Rollers
19. Power cord and plug



20 21 22 23

Remote control

1. ON | OFF
2. Menu
3. Auto Programme
4. Manual setting
5. Move the footrest up/down
6. Weightless position
7. Pause
8. Back
9. Advanced setting
10. Move the backrest and footrest up/down

SCREEN SETTING

Shoulder height

Setting



Quick access remote control



Remote control



- Auto Program**
- Demo** Demo programme of all functions
 - Yoga** Targeted stretching massage activates your body and has a stimulating effect on your whole being.
 - Relax** Relaxation for muscles and bones promotes blood flow.
 - Ease ache** A deep massage of the acupuncture points which helps to relieve tense spots
 - Fatigue Recover** Penetrating massage techniques (pressure and kneading) provide relief for your joints. Ideal massage for strengthening and relieving your back and legs.
 - Full Air** All airbags and foot rollers are active
 - Neck | Shoulder** Massage programme focussing on the upper body
 - Back & Waist** Massage programme focussing on the lower body



- Manual Function**
- Message Mode**
 - Message Area**
 - Air**
 - More**
- Message Mode**
- Stop** Stop all massage functions.
 - Knead OFF** Massage technique to relieve tension with 3-stage adjustable and speed.
 - Flap OFF** 3 adjustable settings for speed and width.
 - Knead & Flap OFF** Combination of kneading and tapping. 3 adjustable speed settings.
 - Shiatsu OFF** Shiatsu stimulates specific parts of the body and mobilises the muscles. 3 adjustable settings for speed and width.
 - Knock OFF** Tapping massage facilitates blood flow and relaxes tense muscles. 3 adjustable settings for speed and width.

Remote control

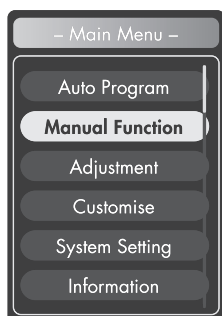

- Massage at a fixed point
- Partial massage in a certain area of the body
- Massage in the upper body area
- Partial massage in the upper back area
- Partial massage in the lower back area
- If no other massage mode is activated, the Rolling function can be selected.

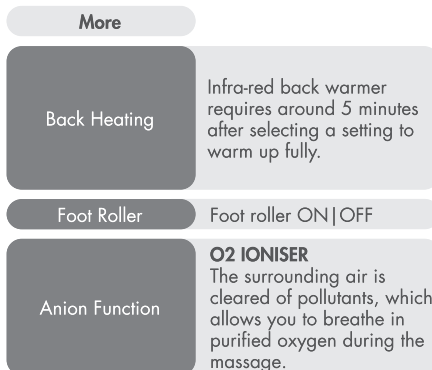
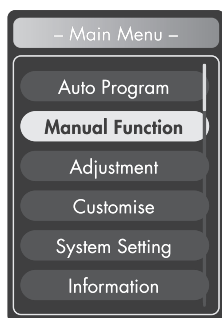
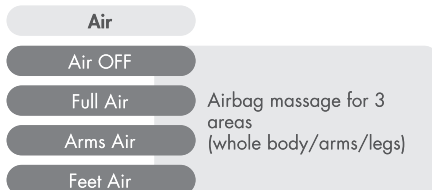
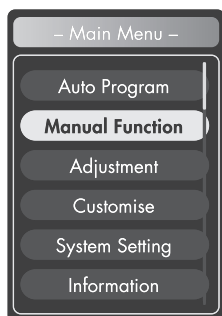

Remote control

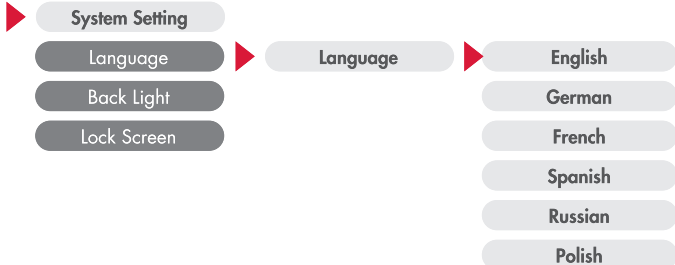
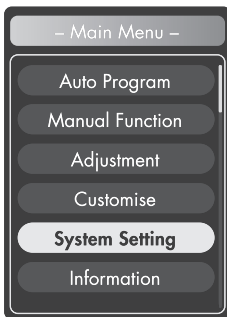
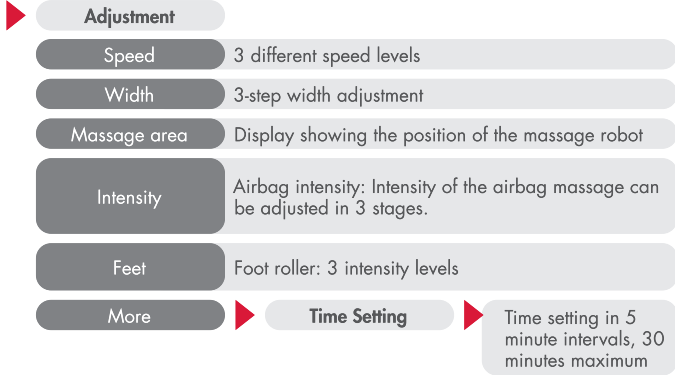
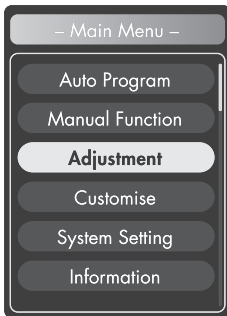

Remote control

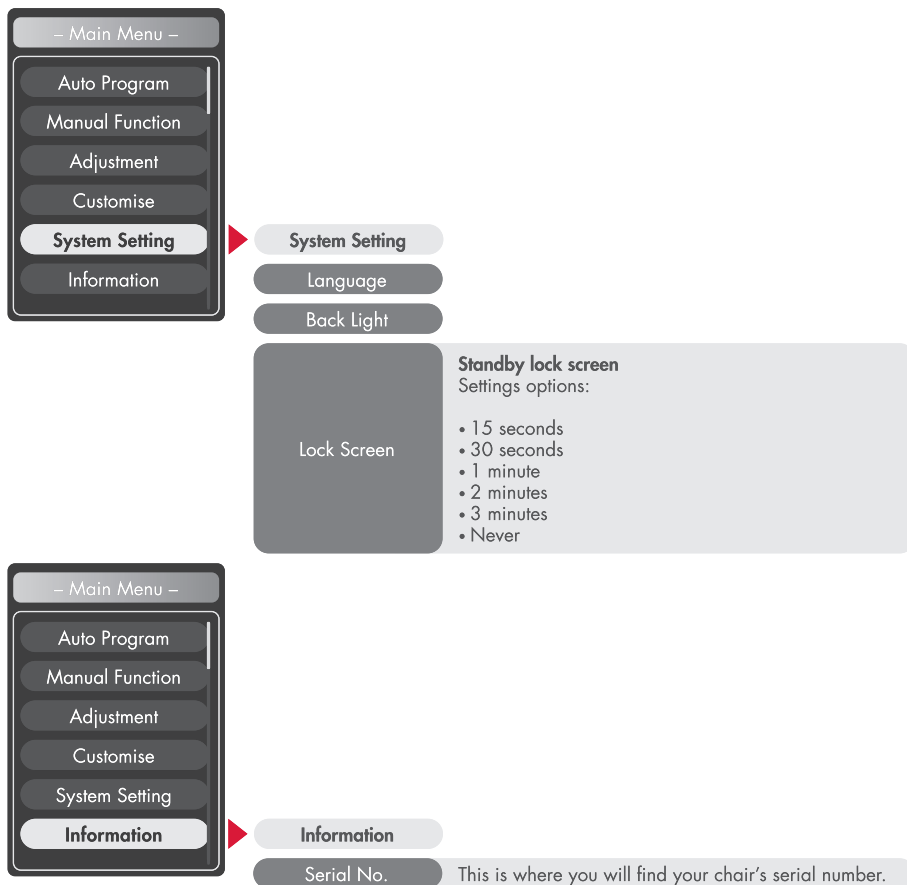

Starting up

1 – ATTACHING THE SIDE PARTS

- a) First locate the connector and the air hose, which can be found on the side of the seat part (Illustration 1).
- b) After feeding the connector and the air hose through the metal device, link each connection with its counterpart on the armrest. Please ensure when plugging in the cables that you always plug in the same colours together! (Illustration 2 & Illustration 3).

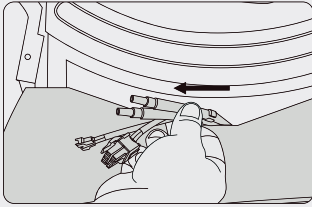

Illustration 1

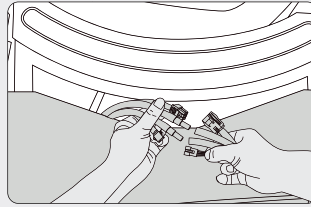

Illustration 2

- c) Once you have joined the connections together, wrap the connections in the dust cover that is attached to the armrest under the connections. Feed the protruding cables back into the seat part. Be careful that the plug-in connectors and the air hose do not bend or jam. (Illustration 4)

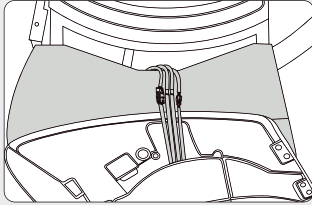

Illustration 3

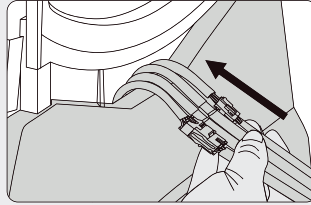

Illustration 4

- d) Position the rear of the side part so that it overlaps with the holes on the seat and secure it using the 2 screws that are included in the delivery. (Illustration 5)
- e) Then take the decorative screen and clip it into the slot above the screws. Please note that the screens are marked with left and right on the inside. (Illustration 6)

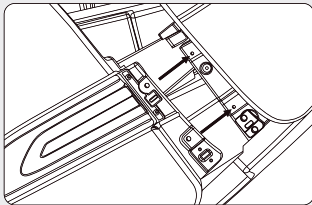

Illustration 5

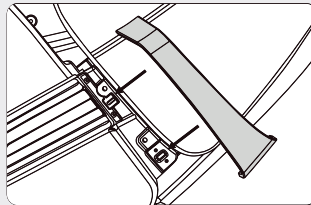

Illustration 6

Starting up

Now secure both side parts to the front of the seat. Two screws are required for this on both sides. Position the mounting bracket of the side part with the two holes towards the front of the seat part, overlapping with the mounting piece and tighten the screws firmly. Ensure that the hook on the side part is hooked onto the connecting piece of the seat part before tightening the screws (Illustration 7, Illustration 8 & Illustration 9).

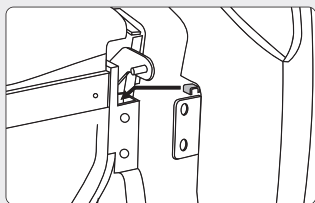

Illustration 7

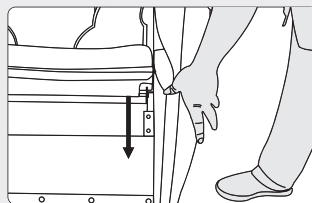

Illustration 8

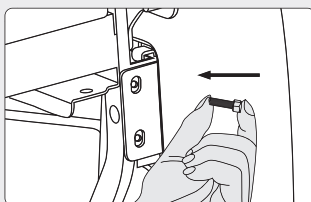

Illustration 9

Repeat these steps on the other side.

2 – ATTACHING THE FOOTREST

- First attach the rotating shaft to the fixed axle. Ensure that the R-bolts are the correct way round (Illustration 1).
- Once the fixed axle is aligned and combined (Illustration 2), join the pieces together.

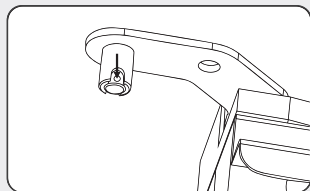

Illustration 1

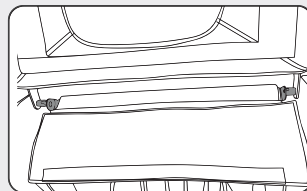

Illustration 2

Starting up

c) Tighten the R-bolts on the other side of the footrest as shown in Illustration 3.

d) Assembly complete (Illustration 4)

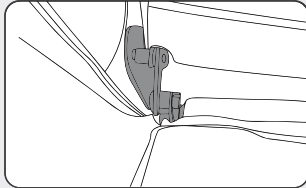

Illustration 3

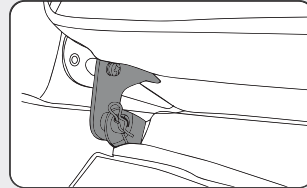

Illustration 4

NOTE

- To avoid injuries and damage to the product, the footrest should not be lifted from the outside or pressed down. (Illustration 1)
- In order to avoid sitting in an uncomfortable position, make sure that the massage mechanism has not stopped in an upright position in the seat cushion. Fig 2:

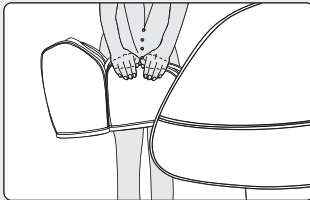

Illustration 1

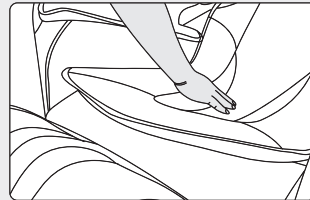
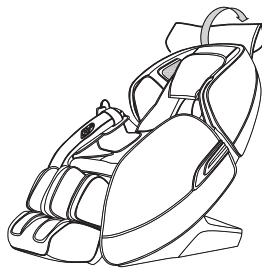

Illustration 2

3 – FITTING AND USING THE HEAD AND BACKREST CUSHION

Please connect the backrest cushion as shown in (Illustration 1) using the practical zipper on the massage chair. Please fasten the pillow using the Velcro strips on the upper part of the back cushion (Illustration 2). To clean the backrest cushion, you can easily separate it from the chair by pulling the zipper. We would strongly advise that you do not use the massage chair without the backrest cushion.



Zipper

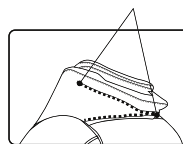

(1)

Velcro strip

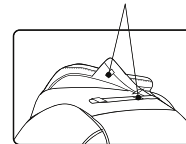

(2)

Starting up

4 – FLOOR PROTECTION

In order to prevent excessive wear and tear of your floor covering due to the heavy weight of the massage chair, we recommend placing carpet or similar underneath the chair.

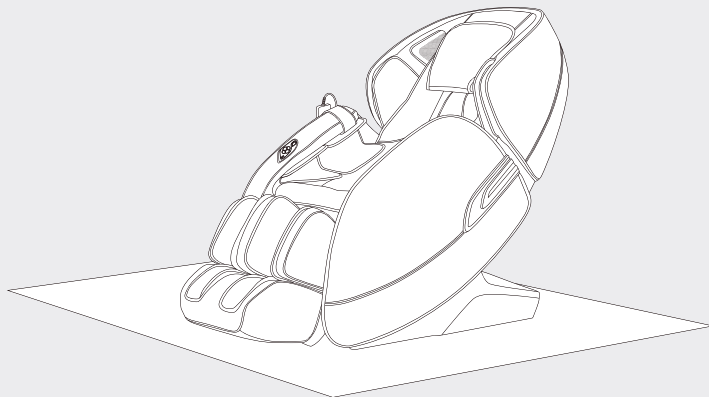

NOTE

The massage chair should not be pushed over uneven or delicate floor surfaces, but should be carried by at least 2 people. To do this, lift the chair using the handle on the back section and the footrest. This way the footrest is completely folded up.

5 – SWITCHING ON THE POWER SUPPLY



Connection procedure

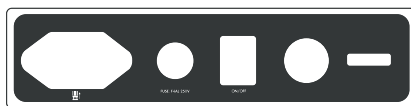

Electrical power switch

Starting up

6 – FINISH MASSAGE

- a) Pressing the power button during a massage stops all massage functions, and both the backrest and the footrest return to their original position.
- b) Unplug the massage chair once you have finished using it.

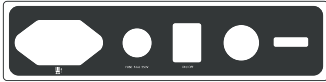

Switch position and power supply



Connection procedures

7 – TRANSPORTATION

Ensure that all cables are far from the ground. Slide the seat on the backrest to the desired position and carefully set it upright again.

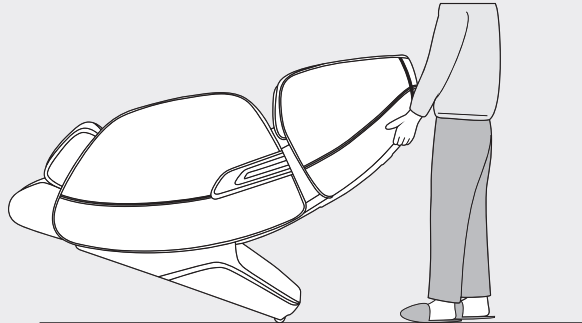

NOTE

Before transportation the electric power supply must be switched off and the power cable with the remote control cable must be disconnected.

Specials

SHIATSU

SHIATSU

Shiatsu (finger press) is a form of body therapy originating in Japan. The massage technique consists of soft, rhythmic, far-reaching stretches and rotations. The aim of Shiatsu is to simulate individual parts of the body and to mobilise the muscles.



2D MASSAGE

The intelligent 2D massage mechanism allows the massage chair to measure your back to determine a more exact position of the sections of the spine.



KNEADING

Skin and muscles are either clasped and kneaded between the thumb and the index finger or with both hands. This massage technique is used in particular to ease tension.



FLAP

Circulation in the muscles is stimulated and the tendons are encouraged to stretch by means of light tapping with a cupped hand, which also reduces tension at the same time.



TAPPING

Short, tapping movements are performed with the edge of the hand, the palm or the fist. This promotes blood circulation in the skin and softens tense muscles. If tapping is performed at lung height, this can improve the release of mucus in the lung.



KNEAD & FLAP

A massage combination of kneading and flapping.



ROLLING

Pleasant alternation between relaxation and releasing the muscles – also perfectly suited for a final massage, for relaxation and recovery of the muscles.



CARBON HEATING

Deeply penetrating Carbon infrared heat, blood vessels expand, the blood flow increases and the muscle tone is reduced. In addition, it carries out a highly beneficial effect on nerve cells, which are responsible for reporting pain to the brain.

Specials



GUA SHA

The scraping technique of -GuaSha- with gentle pressure opens up superficial blood vessels and stimulates blood circulation. GuaSha is often applied in combination with acupressure 'shu points' for additional stimulation of the whole body for an extra soothing massage experience.



AIR COMPRESSION

Rising and receding airbags have a pumping motion which produces natural muscle reflexes. This is particularly beneficial in the calf and foot area.



BLUETOOTH

Wireless data transmission.



BRAINTRONICS

Braintronics® technology synchronises your brainwaves through audio stimulation. Combined with a specially developed massage programme your stress-ridden body will be able to relax.



SL-SHAPE

Thanks to the „SL“ curve rail technology, which has been approved from human engineering, the range of the massage technology is up to 135cm. This method allows you to enjoy a personal full-body massage from head to thigh and supports the maintenance of the „S“-shaped spine.



ZERO SPACE

For the lying-position the massage chair moves forward and therefore requires very little distance to the wall behind. Space saving and comfortable!



ZERO GRAVITY

You put yourself in the position of an astronaut – that “weightless feeling”.



AUTOMATIC

9 specifically developed automatic programmes for the whole body, which offer a big range of different massage techniques. Additionally you can also turn on the heating function, if you'd like.

Specials



MEMORY

Using the intelligent memory function the massage chair remembers your favourite massage exactly and begins immediately without a scan. You have the opportunity to save two programmes with different buttons (M1 & M2).



BACK AREA

An individual applicable to any size massage area.



ADJUSTABLE FOOTREST

The footrest can be extended, this way it is adaptable to different body sizes.



QUICK START

With one touch the quick start buttons in your armrest allow you to control the most important functions.



ADJUSTABLE PILLOW

If necessary, the double cushion can be placed to reduce the neck and shoulder massage intensity.



RECLINING POSITION

The adjustability of the backrest and footrest contributes to personal well-being of the body position.



HUMAN HANDS FEELING

Specially designed massage heads imitate the hand motion of a professional masseur. The maximum stretch space is 6,5 cm, and the maximum stretch angle is 41 degrees, so the mechanical hands can do effective massage to human cervical vertebra thoracic vertebra and lumbar vertebra.



ADJUST SHOULDER

The massage heads can be moved upward or downward to a suitable position in the shoulder area.

Specials



AIR INTENSITY

Adjustable airbag massage intensity.



AIR AREA

Three air pressure modes (full body, arm and leg / lower body).



SPOT

The massage heads can massage a particular spot.



SPEED

Massage speed is adjustable.



WIDTH

The distance between the both massage heads can be set (narrow, medium and wide).



MUSIC

Further relaxation and fun with the music function.



ACUPRESSURE POINTS

Key acupressure points are massaged.



O2 IONIZER

Polluted air around you will be neutralized and you will breathe purified oxygen during your massage.

Specials



USB-CHARGER

While you relax, the integrated USB port can supply, for example, your phone with power.



YOGA

Targeted stretch massages activate the body and have an invigorating effect on the whole of the body.



ARTHROSE TRACTION

Arthrosis Traction consists of gentle stretching pressure. It has a stimulating effect on the cartilages, which enhances the transport of bodily fluids, nutrients absorption and can alleviate symptoms of arthrosis.

Troubleshooting

FAULT	EXPLANATION
<ul style="list-style-type: none"> The noise of the engine is audible during use. 	<ul style="list-style-type: none"> This is a normal operating noise.
<ul style="list-style-type: none"> The remote control does not work properly. 	<ul style="list-style-type: none"> Ensure that the mains plug is properly inserted into the socket and that the power switch is switched on. Please check the cable of the remote control.
<ul style="list-style-type: none"> The device stops operating. 	<ul style="list-style-type: none"> The chair switches itself off automatically once the pre-set runtime has been reached or after excessive usage. This ensures the chair has a long operational life.
<ul style="list-style-type: none"> The braintronics programmes won't start. 	<ul style="list-style-type: none"> Make sure that the braintronics app is installed and that your account is activated. In addition, please check whether the Bluetooth® connection between your smart-phone and the massagechair persists.

Storage | Maintenance

- If the device is not used for a longer period of time, the power cable should be wound up and the device should be stored in a dry environment.
- Never store the device at high temperatures or in proximity to open fire. Avoid prolonged exposure to sunlight.
- Please only use commercially-available artificial leather care products for cleaning. Do not clean it with thinner, benzene, or alcohol at any time.
- If the device is on an uneven surface, do not roll or push it; lift it up in order to move it.
- Please take breaks after each use and do not use the device a number of items without pauses.

Specifications

Dimensions:	upright: 81 x 119 x 147 cm reclining: 81 x 92 x 176 cm
Weight:	96 kg
Voltage:	220-240V ~ 50/60Hz
Nominal power:	150 W
Runtime:	20 minutes
braintronics:	21 minutes
Certificates:	



EU-Declaration of conformity

Complies with European Regulatory Standards EMC 2014/30/EU and LVD 2014/35/EU.

Warranty conditions

The retailer guarantees a statutory period of warranty for the product described on the reverse. Warranty is valid from the date of purchase. The purchase date must be documented with proof of purchase. The retailer will repair or replace defective products registered within Germany free of charge. This does not include parts subject to wear such as fabric covers. This requires the defect device to be sent in with proof of purchase before expiration of the warranty period.

The warranty is void if a defect occurred e.g. due to outside influences or as a result of a repair or modification not performed by the manufacturer or an authorised dealer. The retailer warranty is limited to product repair or replacement. Under this warranty, the manufacturer or the retailer shall have no further liability and is not responsible for damages due to failure to observe the instructions for use and/or improper use of the product.

If after examining the product, the manufacturer determines the warranty claim is not for a defect covered by the warranty or that the warranty period has expired, the customer is responsible for the costs of the inspection and repair.

Legal notice: None of the contents have any healing value. The diagnosis of and therapy for illnesses and other physical disorders requires treatment by a doctor, alternative practitioner or therapist. The statements are exclusively informative and should not be used as a replacement for medical treatment. Every user is instructed to carefully assess their situation and, where necessary, consult a doctor to determine whether using the product is encouraged in their own unique case. Every use or therapy is undertaken at the user's own risk. We dissociate ourselves from any healing properties or commitments.

Casada International GmbH
Obermeiers Feld 3
33104 Paderborn, Germany
info@casada.com
www.casada.com

Copyright Images and text are subject to the copyright of CASADA International GmbH and may not be used without express consent.
Copyright © 2019 CASADA International GmbH.
All rights reserved

