



< timetorelax

Since the company was founded back in the year 2000, the name CASADA has become synonymous with high-quality products in the wellness and fitness sector.

Today, CASADA devices are available worldwide. Continuous development, unmistakable design and a strict focus on improving quality of life are just as much characteristic of CASADA products as reliable and top-class quality.

Congratulations!

By purchasing this massage chair you have demonstrated an awareness for your health.

So that you can benefit from the advantages of this device for a long time, we would ask that you read and observe the safety instructions carefully.

We very much hope you enjoy using your personal AlphaSonic III.

Table of Contents

Safety instructions.....	42
Contraindications.....	43
Troubleshooting	44
Storage Maintenance.....	44
Specifications.....	44
Equipment Functions.....	45
Assembly and Installation	46
Remote Control.....	50
Usage and Controls	68
Specials.....	72
EU-Declaration of conformity	77
Warranty conditions	77

Safety instructions



Please read the following instructions carefully before using your massage chair, to ensure that it functions properly and with optimal efficiency. Please retain these operating instructions for further use!

- The massage chair conforms to recognised technical principles and the latest safety regulations.
- The massage chair is equipped with heated sections. Persons who are sensitive to heat should take care when using the product. (ICE 60335-2-32)
- The massage chair does not require maintenance. Any possible repairs may only be carried out by authorised experts.
- Improper use and unauthorised repairs are not permitted for safety reasons and lead to loss of warranty.
- In order to avoid injury please do not stick your fingers between the massage rollers.
- Never touch the mains plug with wet hands.
- Do not allow the massage chair to come into contact with water, high temperatures or direct sunlight.
- Do not use the massage chair in an environment with high humidity levels e.g. in the bathroom.
- Do not use the massage chair in an area with insufficient space or in an area where the ventilation is covered and a supply of fresh air is not guaranteed.
- To avoid the danger of short-circuits, disconnect the massage chair from the power supply if it is not in use for a long period of time.
- Do not use any damaged cables, plugs or loose sockets.
- If cables/plugs are damaged, they must be replaced by the manufacturer, a service representative or by qualified personnel.
- In the case of malfunction, immediately disconnect the product from the mains.
- The company disclaims any liability for damage if the product is in use inappropriately or incorrectly.
- Do not exceed the daily recommended massage duration of 30 minutes in order to avoid excessive strain on the muscles and the nerves.
- To avoid damaging the massage chair, never use pointed or sharp objects.
- In order to reduce the danger of short circuits or fire, it is essential to use only sockets that fit the plug and to ensure that the plug is fully inserted into the socket.
- Disconnect the massage chair from the power supply after use and before cleaning.
- Do not allow children under 14 to clean or maintain the product without supervision.
- If an unexpected power failure occurs during use, immediately set the switch to the OFF position and disconnect the plug in order to avoid damage to the massage chair.
- Do not use the massage chair if the electric cables are wet or damaged.
- Children under the age of 14, people with disabilities and frail people must be supervised at all times when in the vicinity of the massage chair or when using the massage chair.
- Do not use the massage chair immediately after consuming a meal or when under the influence of alcohol.
- Only use the product for the purpose described in the operating instructions.
- Please only use accessories provided by the supplier.
- To prevent damage, please do not stand, sit or bounce on the footrest.
- To avoid damage or injury, do not try to sit on the armrests or backrest.
- Please clean your massage chair regularly and prevent foreign bodies from penetrating the crevices of the massage chair.
- Please do not pull directly on the mains cable.
- When adjusting the position of the footrest or the backrest, please ensure that there are no other objects underneath, in particular no children under the age of 14.
- The product is only intended for domestic use.
- If the flexible power cable becomes damaged, another flexible cable designated for the same purpose must be used or a suitable replacement cable must be purchased from the manufacturer or their service point.

Contraindications

If you are unsure whether you should use the massage chair, consult your doctor by all means.

- Use of the massage chair is prohibited during pregnancy or in the case of one or several of the following complaints: Recent injuries, thrombotic diseases, any kinds of inflammations and swellings, and cancer. If you are undergoing treatment for illnesses or conditions it is recommended that you consult with a doctor before getting a massage.
- Persons with physical, cognitive or mental impairments or persons lacking experience and knowledge should only use this chair under the supervision and guidance of persons responsible for their safety.
- In order to avoid any discomfort or danger when using the massage chair, we would ask the following people to consult a doctor before using the product:
 - Non-ambulant persons
 - Persons receiving medical treatment
 - Patients with back pain and persons with spinal problems / curvature of the spine.
 - Persons with pacemakers
- If you experience pain during the massage, stop using the product immediately.
- If you injure yourself whilst using the chair, seek immediate medical treatment.
- Please do not massage any reddened, swollen or inflamed areas of the skin.
- This massage chair is intended to be used only for home wellness massages and is not a medical massage device. It can therefore not be used as a substitute for specialist medical treatment.
- We recommended that you use the massage chair for 30 minutes on a daily basis. Individual areas of the body should be massaged for a maximum of 15 minutes at a time, as excessive massaging can otherwise be counter-productive.
- This product is not suitable for children under the age of 14.
- Children under the age of 14 must be supervised. Ensure that children do not play with the massage chair.

"BRAINTRONICS®" CONTRAINDICATIONS

- Psychoses (e.g. Schizophrenia, bipolar disorder, endogenous depression)
- Personality disorders
- Epilepsy and similar seizure disorders
- Heart conditions
- Diseases of the central nervous system
- Thrombosis
- Endogenous depression
- ADHD (under-active)
- Recent heart attack or stroke
- Mental disability
- Addictions such as to drugs or alcohol or dependency on medication
- Regular intake of psychotropic drugs
- Pregnancy

NOTE: For ethical and legal reasons, braintronics® should not be used on children and young people without the explicit permission of the legal representatives. Persons for whom meditation may conflict with religious beliefs should refrain from using the product.

Troubleshooting

FAULT	EXPLANATION
<ul style="list-style-type: none"> • The noise of the engine is audible during use. 	<ul style="list-style-type: none"> • This is a normal operating noise.
<ul style="list-style-type: none"> • The remote control does not work properly. 	<ul style="list-style-type: none"> • Ensure that the mains plug is properly inserted into the socket and that the power switch is switched on. Please check the cable of the remote control.
<ul style="list-style-type: none"> • The device stops operating. 	<ul style="list-style-type: none"> • The chair switches itself off automatically once the pre-set runtime has been reached or after excessive usage. This ensures the chair has a long operational life.
<ul style="list-style-type: none"> • The braintronics® programmes won't start. 	<ul style="list-style-type: none"> • Make sure that the braintronics app is installed and that your account is activated. In addition, please check whether the Bluetooth® connection between your smartphone and the massagechair persists.

Storage | Maintenance

- If the device is not used for a longer period of time, the power cable should be wound up and the device should be stored in a dry environment.
- Never store the device at high temperatures or in proximity to open fire. Avoid prolonged exposure to sunlight.
- Please only use commercially-available artificial leather care products for cleaning. Do not clean it with thinner, benzene, or alcohol at any time.

Specifications

Dimensions:	upright: 142 x 82 x 124 cm reclining: 204 x 82 x 90 x cm
Weight:	135,8 kg
Voltage:	220-240V ~ 50/60Hz
Nominal power:	150 W
Runtime:	20 minutes
braintronics®:	21 minutes
Certificates:	



Equipment | Functions

1. Head cushion
2. 3D digital audio
3. Upper arm airbag component
4. Back airbag component
5. Arm airbag component
6. Remote controller placement slot
7. Hand massage with magnetic therapy
8. Seat cushion
9. Legrest
10. Backrest
11. Armrest short cut key
12. Wireless phone charger
13. Armrest
14. LED atmosphere lights
15. Side cover

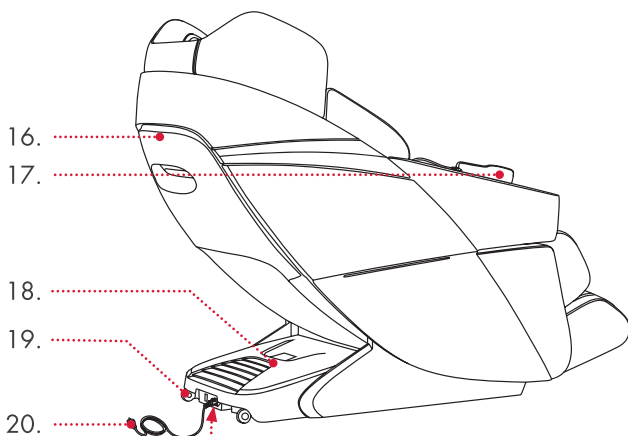
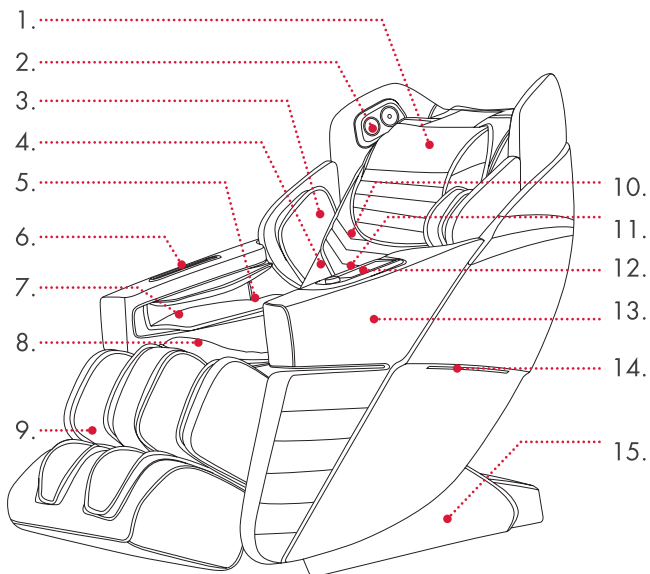

16. Backrest cover
17. Remote controller
18. Electronics safety cover
19. Transport wheels
20. Power cable
21. Main switch
22. Mains input



- 21.
- 22.

Assembly and Installation

INSTALLATION INSTRUCTIONS FOR ARMRESTS

Remove all parts from the boxes and remove the packaging material. Make sure that you do not throw away any small parts with the packaging material. For assembly, you need a Phillips screwdriver or cordless screwdriver with a bit set. When using a cordless screwdriver, please ensure that it is not set too high, as this could destroy the screws or threaded holes.

1. To begin the assembly, the chair must first be set in the upright position. Pick up the remote control and connect it. You will find the connection on the right-hand side at the front part of the seat, while standing in front of the chair (Figure 1). Now plug the chair to the power socket. Make sure the main switch next to the power cable is in I position. Press the on/off button twice so that the chair moves to the upright position. Afterwards, disconnect the chair from the power supply socket.

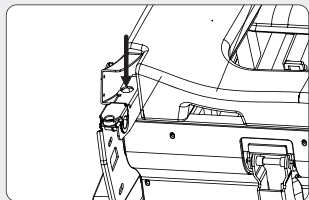

Figure 1

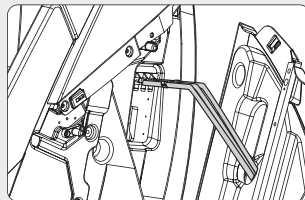

Figure 2

2. Connect the air hoses and plugs with the corresponding parts (which are colour-coded or numbered) on the back of the chair (figure 2).
3. Take the side section and hook it into the fixture on the frame of the chair using the hooks in the centre (figure 3).

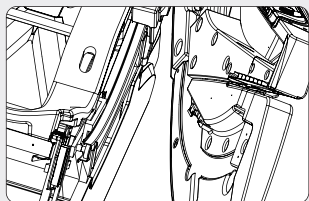

Figure 3

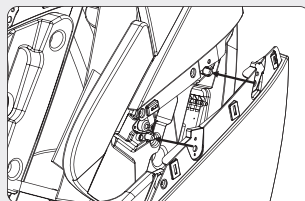

Figure 4

4. Place the rear side panel on the 2 plastic pins that have holes into the side panel. Make sure that the cables and hoses are not squeezed (Figure 4).
5. Fix the rear side of the side panel with 2x M5 screws (Figure 5).
6. Next, use 2x M5 screws to secure the side section. The threads are located on the inside at the front (figure 6).

Assembly and Installation

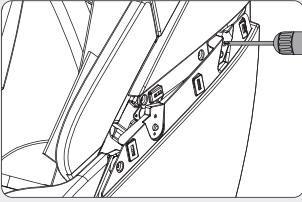

Figure 5

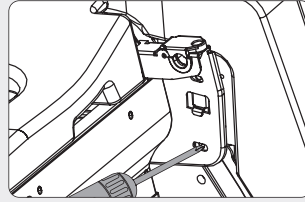

Figure 6

7. Use the matching decorative cover and place it with its clip over the holes on the armchair and click it in place (Figure 7).

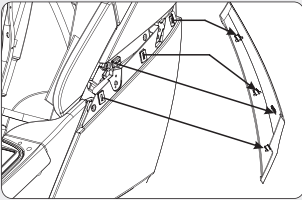
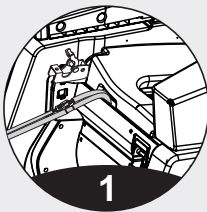

Figure 7

INSTALLATION FOR LEGREST

1. Release the bracket for the foot section by removing the cross screws (Figure 2).
2. Place the footrest in front of the chair and connect the wires and the air hose (Figure 1). Raise the footrest into the fixture of the bracket using the two bolts on the left and the right.



1

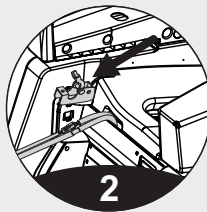

2

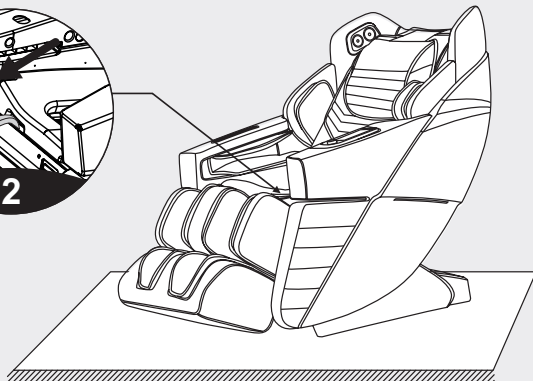

Assembly and Installation

3. Shut the bracket (Figure 3) and tighten it with the previously removed screw (Figure 4). Apply this to each side.
4. Make sure that the footrest is correctly installed. Grab the footrest and move it manually a few times from the bottom to the top. If you do not notice anything abnormal, the footrest is installed correctly.

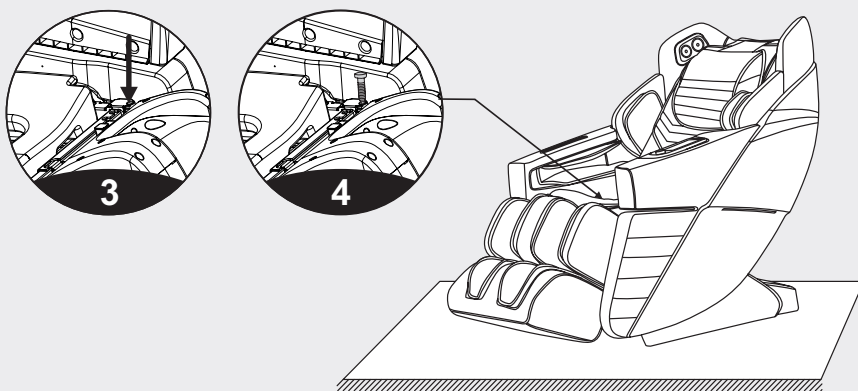

INSTRUCTIONS FOR REMOVAL AND USE OF HEAD CUSHION AND BACKREST

The use of the head cushion can reduce the intensity of kneading massage on the neck and shoulders. You can decide whether to use the head cushion according to your own needs (the head cushion is recommended). The backrest and the back cushion are connected by a zipper (1). The head cushion and the backrest are connected by a hook-and-loop fastener (2).

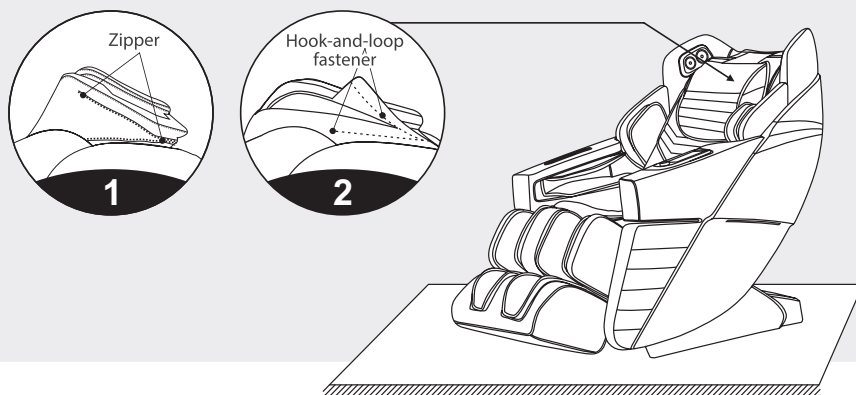

Assembly and Installation

FLOOR PROTECTION

The prolonged heavy pressure of the massage chair may cause scratches on the floor. Thus, put a carpet or cushion on the floor where the massage chair is placed to avoid this damage.

NOTE: Do not move the massage chair with its wheels on the rough ground or in a narrow space.

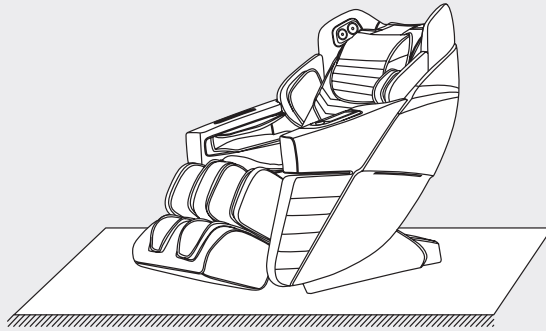

INSTRUCTION FOR MOVEMENT

Ensure that no cables are on the floor. Tilt the backrest backwards to a certain degree (whereby its centre of gravity remains on the wheels), push the chair forwards or backwards with your hands and finally return it slowly and gently to its basic position.

NOTE: Before you move the chair, you have to switch off and disconnect the power cable.

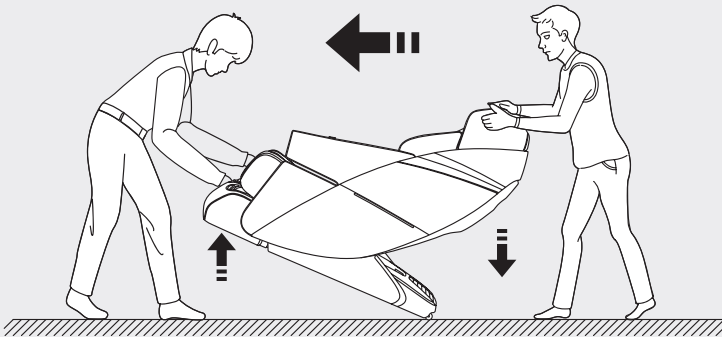

NOTE: Please move the chair with at least two persons. One person should lift the chair from the front in order to place it on its wheels!

Remote Control



Remote Control

- 1.** Display: TFT color LCD showing the massage functions in the running state.
- 2.** On / Off: Switches the massage chair on and off.
- 3.** AUTO Key: Enter the automatic function mode selection interface. For more information, refer to the section "Automatic programme".
- 4.** Zero-Gravity key: Adjust the angle of the massage chair for zero gravity. There are a total of four modes to choose from (i.e. 1st pressing is Level 1; 2nd pressing is Level 2; 3rd pressing is Level 3; and 4th pressing makes the massage chair restore to the original state).
- 5.** UP key: Up navigation key select an object upward in the menu, or adjust the massage position upward.
- 6.** OK: Confirm the selected massage function for massage.
- 7.** Left button: Left navigation key return to the previous menu, or select an object leftwards.
- 8.** Down key: Down navigation key select an object downward in the menu, or adjust the massage position downward.
- 9.** Retract footrest: Press and hold this button to retract the footrest. Release to stop.
- 10.** Legrest Up key: Adjust the legrest upward according to your own massage needs for the most comfortable massage posture.
- 11.** Legrest down key: Adjust the leg rest downward according to your own massage needs for the most comfortable massage posture.
- 12.** Extend footrest: Press and hold this button to extend the footrest. Release to stop.
- 13.** Pause button: Pause all the massage functions currently in service. Press this button again to continue to run all the massage functions before such pause.
- 14.** Menu button: Enter the main menu selection interface.
- 15.** Right key: Right navigation key: enter the submenu, or select an object rightwards.
- 16.** Linkage sitting key: According to the required massage angle, simultaneously adjust the linkage sitting function of the backrest and the leg rest for the most comfortable linkage sitting massage posture.
- 17.** Linkage lying key: According to the required massage angle, simultaneously adjust the linkage lying function of the backrest and the leg rest for the most comfortable linkage lying massage posture.

Remote Control

TURN ON THE POWER SUPPLY

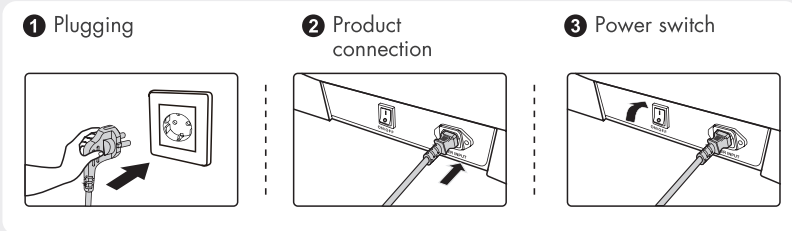

MESSAGE FUNCTION CONTROL OPERATION:

2. Start message

Press the switch to start the message. Enter the start-up screen. The backrest will maintain the default position, and the leg rest will be slightly raised. Just wait for any one of automatic function programs in the automatic function selection interface to start massage. If no "AUTO" function is selected within 5 minutes, the massage chair will automatically shut down.

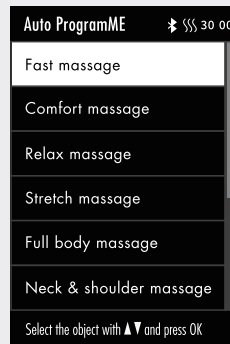

Remote Control

BODY SENSING

1. Lying angle adjustment

After selecting any automatic function, the positions of the backrest and the leg rest will be adjusted to the preset angles. After the angle is adjusted, the massage chair will automatically perform the shoulder position and body shape detection.

NOTE: The fast massage function can only detect the shoulder position, other modes are for full body shape and position detection. Wait for completion of this detection or alternatively press "OK" to skip the step.

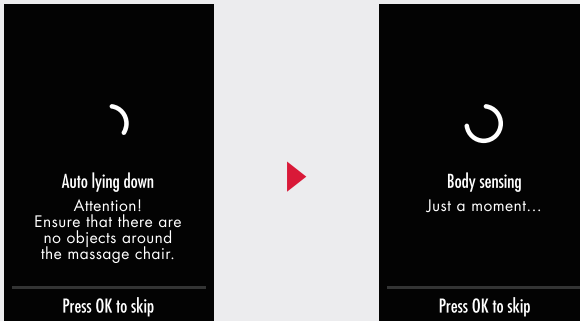

2. Shoulder position adjustment

After detecting the shoulder position, the buzzer beeps. If there is a difference from the actual shoulder position, adjust it to one of the 11 levels by pressing the "Up" or "Down" button. The massage will start by default if no shoulder position is detected. If no adjustment is made within 10 seconds, the massage functions starts automatically. Press "OK" directly to start immediately.

NOTE: During the massage, you can press the "Left button" or the "Right button" on the navigation interface to select the "Shoulder adjustment" menu, confirm with "OK" and call up the shoulder adjustment interface. You can also use the "Up" or "Down" key to adjust the shoulder position.

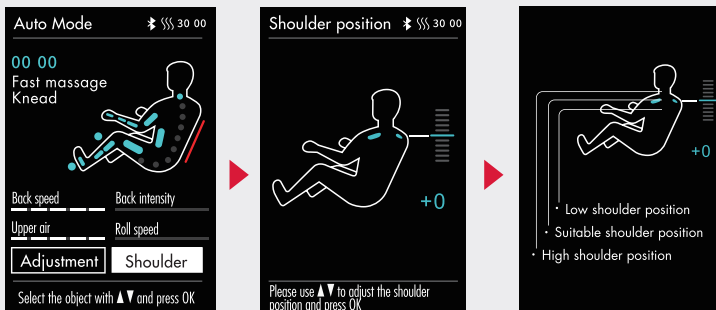

Remote Control

Button	Description
	To detect the shoulder position after starting the massage programmes, select the "Shoulder position adjustment" function. You can press the "Up" or "Down" button to adjust the height of the shoulder position.

3. Massageposition

- After entering the massage programmes, you can adjust the massage position by pressing the "Menu" key on the remote control and choosing "Manual function"; select one of the manual functions. Use the "Left button" to return to the information screen (i.e. the information screen changes to the manual function screen).
- When the massage area shows a fixed point or a partial area, you can directly press the "Up button" or the "Down button" in the manual function interface to adjust the massage robot up or down.
- If the massage area shows neither a fixed point nor a partial area, select "adjustment" in the manual functions interface, then "Massage area" to select a fixed point or partial area. The "Left button" returns you to the information screen. Next, you need to press "Up" or "Down" to adjust the massage robot up and down.

NOTE: You cannot set the massage position while the massage chair is in the automatic programme mode.

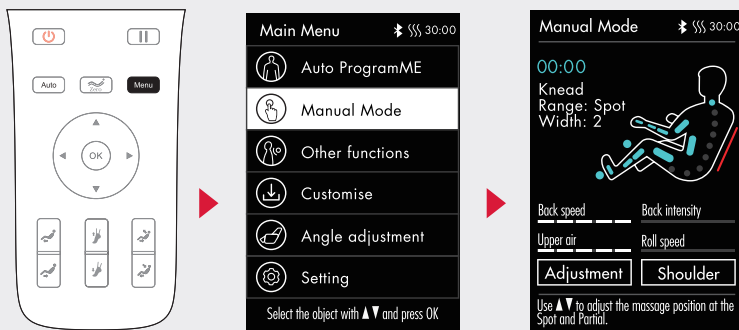

Remote Control

AUTO PROGRAMM

- Press the "Menu key" to enter the main menu. Press the "Up key" or the "Down key" to select an automatic function. Press "OK" (or press the "AUTO key" directly in the information display) to confirm the selection of the automatic massage function.
- There are 21 individual automatic massage functions available. Open the automatic message interface. Press the "up key" or the "down key" to select any automatic message programme. It automatically returns to the information screen, whereupon the information screen for the automatic function appears.



Function	Description
Fast massage (demo version)	Experience all the massage effects quickly.
Comfortable massage	The most comfortable massage experience.
Relaxing massage	Gentle and comfortable deep massage to relieve your body fatigue and relax the body.
Stretching massage	Stretch your legs and waist through the leg rest and the backrest to effectively remove fatigue,relieve joint pain and restore vitality.
Full body massage	Deep massage to rejuvenate your body.
Neck & shoulder massage	With the unique massage technique for the neck and shoulder, the effective massage for the cervical spine and scapula can be performed to relieve the neck and shoulder pain and reduce fatigue on the neck and shoulder.

Remote Control

Back & waist massage	Focus on the back and waist massage to relieve the pain on the back and waist.
Full airbag massage	Focus on the full-body airbag massage to achieve full relaxation and deep massage of the body and fully relieve the fatigue and pain from your body.
Stress Relieving	Restore the full body from fatigue and pain; achieve relaxation, improve micro-circulation, and quickly relieve fatigue for the back and limbs.
Energy	After a night of rest, the body can have a rest; the whole body muscles are massaged to quickly wake up the body functions and start a new day of vitality.
Good-night Sleep	Through the massage for the twelve major acupoints for healthcare, it helps the body to adjust balance, quickly improve your sleep and your sleep quality.
Joint Care	Care for the health of all your limbs and joints by pushing, pulling, stretching, and other massage modes.
Neck & shoulder care	The unique massage technique for shoulder and neck helps to promote blood circulation, relieve neck and shoulder pain.
Spine massage	Improve humpback and chest down; massage for each vertebra; care for the spine health; and improve the protrusion of intervertebral disc.
Office Regimen	For sitting in the office for a long period of time, this function can increase physical exercise by massage and improve the body functions.
Sport Recovery	Make you quickly recover from physical fatigue after exercise.
Brain Refresh	Relieve the neck and shoulder pain; promote the blood supply to the brain by massaging the YUZHEN and DAZHU points.
Spine Care	Care for the health of spine and perform improvements for the lack of exercise.
Waist Care	Focus on improving the health of the lumbar spine and alleviating the stiffness of the waist muscles.
Legs Care	Quickly relieve the pain of the lower extremities and the muscle fatigue.
Rejuvenation	Improve the quality of nap and work efficiency.

Remote Control

MANUAL FUNCTION

- Press "Menu Button" to enter the main menu interface. Press "Up Key" or "Down Key" to select the manual function, and press "OK" to enter the manual function interface.
- 11 manual massage techniques/functions: OFF, kneading, Tapping I, Tapping II, simultaneous kneading and tapping, Shiatsu I, Shiatsu II, shoulder lifting, 3D I, 3D II, 3D III, 3D IV, etc.
- After entering the manual function interface, press "Up Key" or "Down Key" to select the required manual massage technique. Press "OK" to confirm. After selecting the technique, you will not automatically return to the information interface. Press "Left Button" to return to the previous interface. After returning to the information interface, you will find that you have entered the information interface of the manual function.

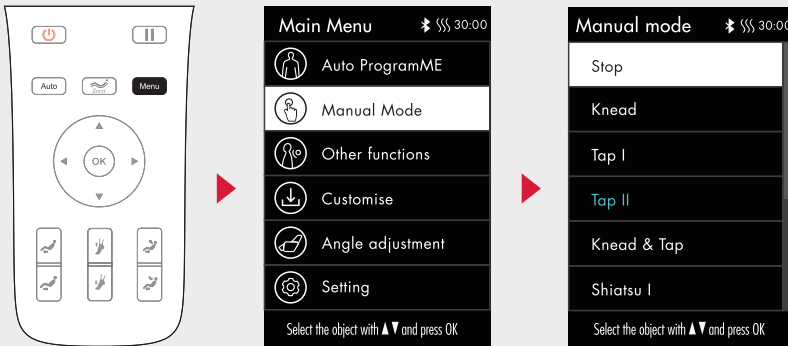

Function	Description	
Kneading	Speed	5 speed levels adjustable
Tapping	Speed, width	
Simultaneous kneading and tapping	Speed	
Shiatsu	Speed, width	5 width levels adjustable
Shoulder lifting	Speed	
3D	Speed, width	

*Width adjustment is not possible for the kneading and tapping functions.

**In 3D massage technique mode, the width of 3D I and 3D II cannot be adjusted; the width of 3D III and 3D IV can be adjusted.

Remote Control

OTHER FUNCTIONS (MAIN MENU KEY – OTHER FUNCTIONS)

- Press "Menu Button" to enter the main menu interface. Press "Up Key" or "Down Key" to select other function icons. Press "OK" to enter another function interfaces.
- After entering another function interface, press "Up Key" or "Down Key" to select the massage function. After selecting any one of the functions, use "Right Button" to enable or disable the function. Then press "OK" to confirm. Press "Left Button" to return to the previous menu interface.

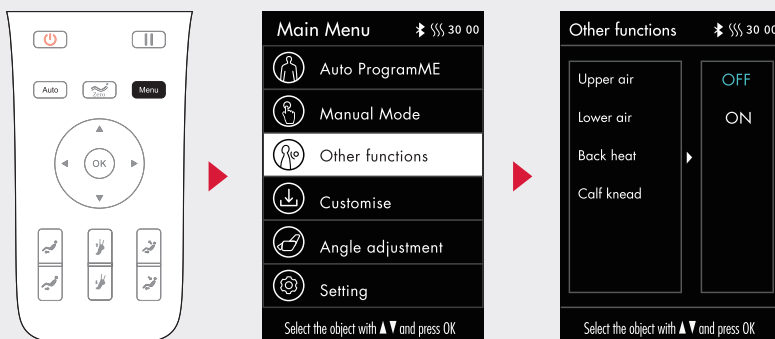

1. Airbag massage for the upper body

Go to other functions in the display. Press the "Up key" or the "Down key" to select the airbag massage function for the upper body. Use the "Right key" to activate or deactivate the airbag massage function for the upper body. Then press "OK" to confirm. To return to the previous menu interface, press the "Left button".

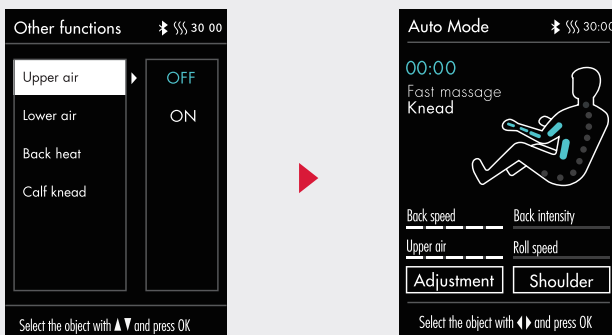

Remote Control

2. Airbag massage for the lower body

Go to the interface: Other functions. Press the "Up" or "Down" key to select the airbag massage function for the lower body. Press the "Right key" to switch the airbag massage function for the lower body on or off. Press the OK button to confirm. Press the "Left button" to return to the previous menu interface.

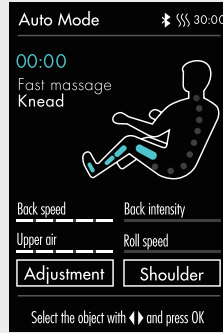

3. Back heating

Enter the interface for Other functions. Press the "Up" or "Down" button to select the back warm-up function, the back surface will warm up after a 3-minute warm-up period. Use the "Right button" to activate or deactivate the function. Then press "OK" to confirm. Press the "Left button" to return to the previous menu interface.

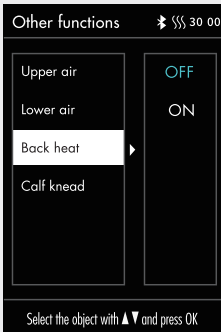

Remote Control

4. Leg kneading

Enter other function interface. Press "Up Key" or "Down Key" to select the leg kneading function. Use "Right Button" to enable or disable such function. Then press "OK" to confirm. Press "Left Button" to return to the previous menu interface.

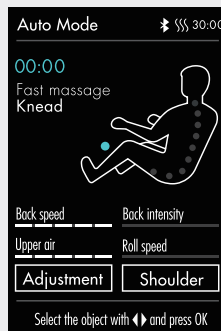
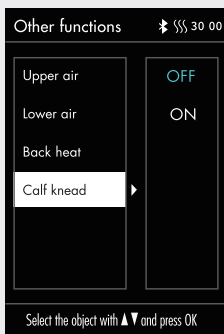

INTELLIGENT STORAGE

1.Storage

- Press the "Menu key" to enter the menu interface. Press the "Up" or "Down" key to select the intelligent memory icon. Press "OK" to enter the Intelligent Memory interface.
- The intelligent memory function includes: M1, M2, M3, M4, and M5 (5 memory positions).
- Storage/Memory Call: Store the massage mode, massage technique, airbag mode and intensity under the current running status, the positions and angles of the leg rest and the backrest, and other massage functions.

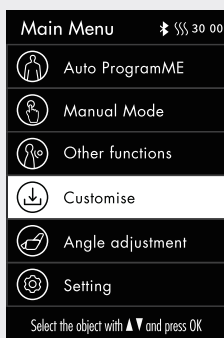

Remote Control

2. Memory Save

- After entering the intelligent storage interface, press the "Up" or "Down" button to select the message function to be stored. To save, confirm with the "OK" key.
- Enter the intelligent memory (memory save) interface. Press the "Up" or "Down" button to select one of the 5 memory locations. Select "OK" to confirm and label the saved message function; press the "Left button" to return to the previous menu interface.

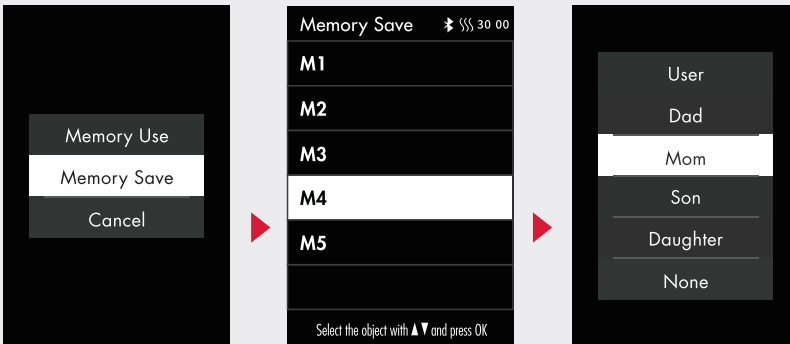

NOTE: Label the stored message function and method (e.g. father, mother, son, daughter or none).

3. Memory use

After you have opened the intelligent storage interface, press the "Up" or "Down" button to select the stored message function. Press the "Left button" to return to the previous menu interface.

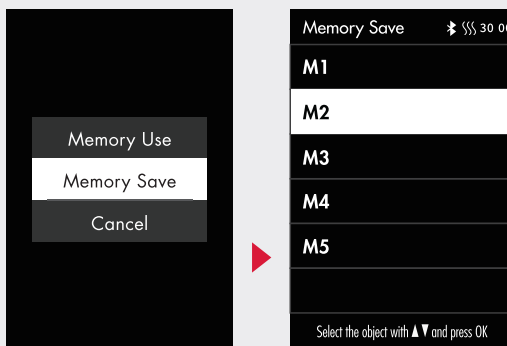

Remote Control

ANGLE ADJUSTMENT

- Press "Menu Button" to enter the main menu interface. Press "Up Key" or "Down Key" to select the angle adjustment icon. Press "OK" to enter the angle adjustment interface.
- After entering the angle adjustment interface, press "Up Key" or "Down Key" to select the desired angle adjustment function. After selecting any angle, press "OK" to confirm the selected angle adjustment. Press "Left Button" to return to the previous menu interface.

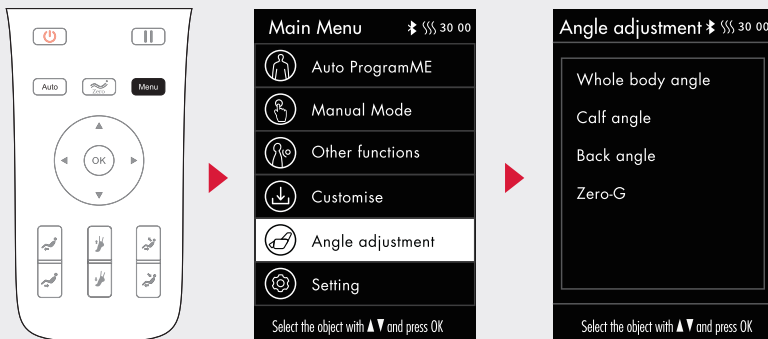

1. Angle for the whole body

Enter the angle adjustment interface. Press "Up Key" or "Down Key" to select the angle function for the whole body. Then press "Up Key" or "Down Key" to adjust the angle for the whole body to the desired angle; press "Left Button" to return to the previous menu interface.

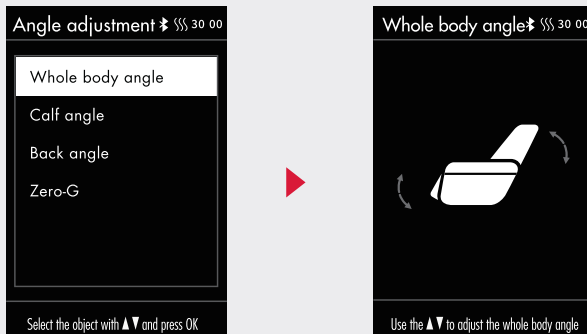

Remote Control

2. Leg angle

Enter the angle adjustment interface. Press "Up Key" or "Down Key" to select the leg rest angle function. Then press "Up Key" or "Down Key" to adjust the legrest angle to the desired massage angle; press "Left Button" to return to the previous menu interface.

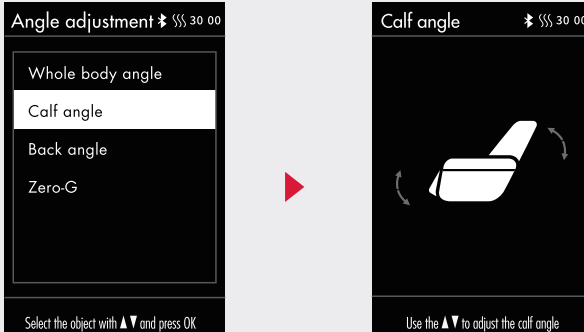

3. Backrest angle

Enter the angle adjustment interface. Press "Up Key" or "Down Key" to select the backrest angle function. Then press "Up Key" or "Down Key" to adjust the backrest lying angle to the desired massage angle; press "Left Button" to return to the previous menu interface.

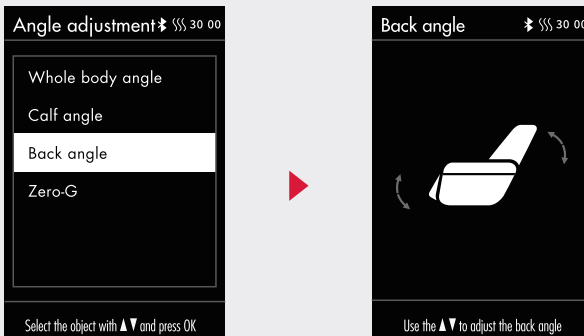

Remote Control

4. Zero Gravity

Enter the angle adjustment interface. Press "Up Key" or "Down Key" to select the zero gravity function; press "OK" to enter the zero gravity interface, and then press "Up Key" or "Down Key" to select OFF, any of Level 1, Level 2 or Level 3 for the zero gravity angle. Then press "OK" to confirm; press "Left Button" to return to the previous menu interface.

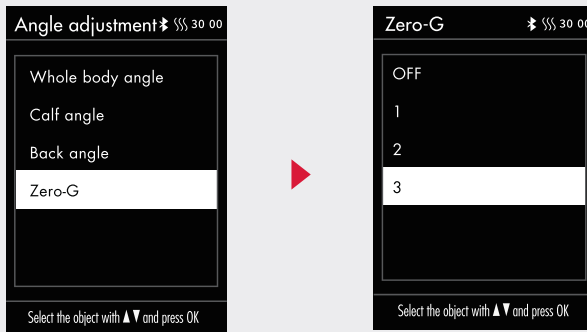

SETTINGS

Press the "Menu key" to enter the main menu. Use the "Up" or "Down" key to select the desired setting function. Select one of the setting functions and then press the "Right" key to choose the selected setting function. Press the "OK" button to confirm; press the "Left button" to return to the previous menu interface.

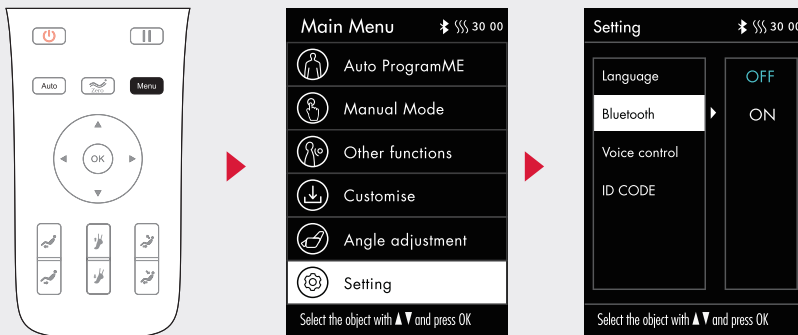

Remote Control

1. Language

Enter the main menu. Press the "Up" or "Down" key to select the language settings. Press the "Right key" to select the desired language; with the "Left key", return to the previous menu interface (the function can be saved, i.e. after selection, switching off and restarting, the last selected state is retained).

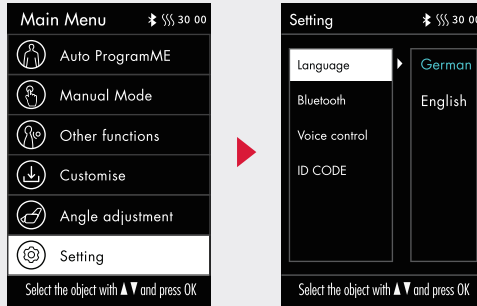

2. Bluetooth

- Bluetooth settings (OFF by default): After the Bluetooth function of the massagechair is enabled, the Bluetooth-enabled audio source device (e.g. mobile phone, tablet) can be connected with the Bluetooth module of the massage chair, and the music played by the audio source device can be wirelessly transmitted to the audio system of the massage chair via Bluetooth for music playback.
- Enter the settings interface. Press "Up Key" or "Down Key" to select the Bluetooth settings. Press "Right Button" to enter the Bluetooth ON/OFF interface. Press "OK" to select the required ON or OFF; press "Left Button" to return to the previous menu interface.

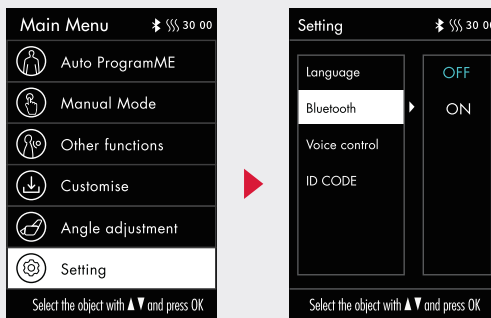

- Select the main menu of your smart device. Select "Settings" and the option "Bluetooth". The Bluetooth function will automatically search for a new Bluetooth device. As soon as you are asked to connect to the device, confirm this in order to connect. Start the "Music Player" on the smart device and select the track to be played.

Remote Control

3. Intelligent Voice Control (AVAILABLE IN ENGLISH ONLY)

Enter the interface for settings. Press the "Up" or "Down" button to select the intelligent voice control. Press the "Right key" to access the intelligent voice control settings. Press "OK" to switch the desired function on or off; (the status of the voice control is saved, i.e. after selection, switching off and restarting, the last selected status is adopted); press the "Left key" to return to the previous menu interface.

NOTE: The wake-up function is not available when the intelligent voice control is deactivated.

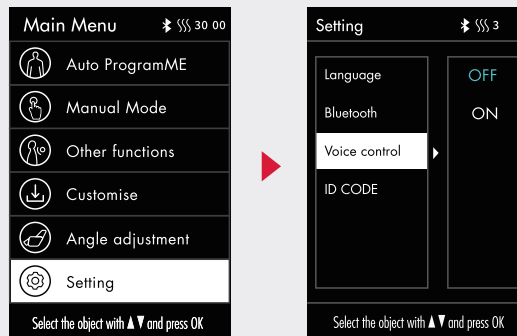

4. Product-ID

Enter the settings interface. Press "Up Key" or "Down Key" to select the equipment ID and check the equipment number of the current device.

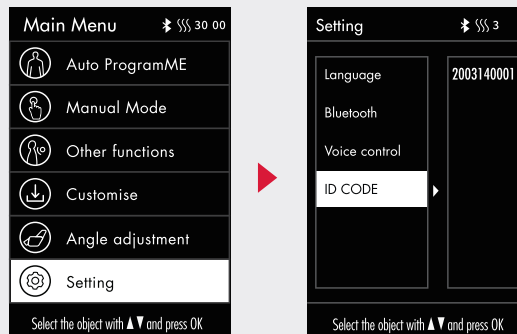

Remote Control

MASSAGE ADJUSTMENT

- In the state of the information interface, press "Left Button" or "Right Button" to select the massage adjustment button, and press "OK" to enter the massage adjustment interface.
- After entering the massage adjustment interface, press "Up Key" or "Down Key" to select the desired massage adjustment function. After selecting any one of the desired massage adjustment functions, use "Right Button" to enter the massage level selection interface. Then press "OK" to confirm the selected level. Press "Left Button" to return to the previous menu interface.

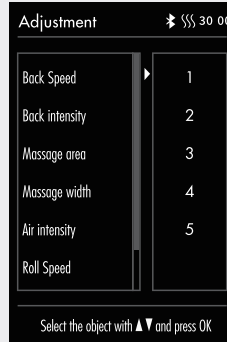
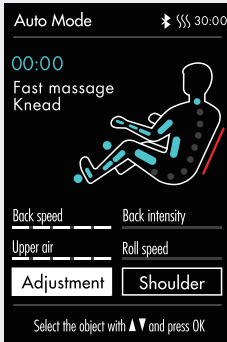

Function	Description
Back massage speed	5 speed levels adjustable
Back massage intensity	5 intensity levels adjustable
Massage range	There are 5 modes for your choice: fixed point, local area, full back, upper back, and lower back
Massage width	5 width levels adjustable
Airbag intensity	5 intensity levels adjustable
Foot roller speed	Choose from 4 modes including OFF and Level 1-3
Massage time	Choose from 4 modes: +10min, +5min, -5min, -10min

NOTE: According to the remaining massage time, when the displayed time is not enough for the addition and subtraction of a certain time, the operation will not be displayed (the upper limit of the time display is 40 minutes). For example: If the display time of the remote controller is 39 minutes, the massage time adjustment range will be: -5min, -10min (+10min or +5min cannot be displayed). The adjustment of airbag intensity can only be used when the airbag function or the automatic function is enabled.





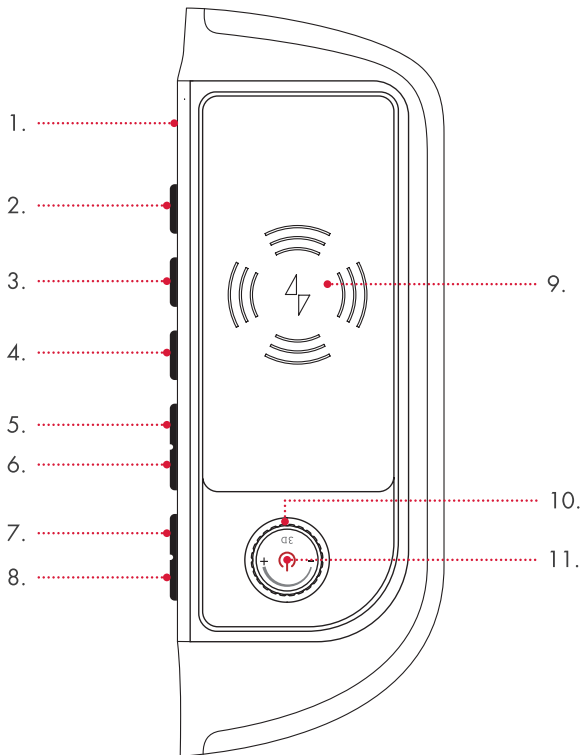



Usage and Controls

KEY CONTROLS IN THE ARM REST



1. Voice control microphone: Built-in voice control microphone.
2. AUTO key: Press it to enable the automatic massage function.
3. Voice control and wake-up button: Short press to enable the voice control function, long press 3 seconds to turn on or off the voice control function.
4. Heat treatment key: Click the key to enable or disable the heat treatment function.
5. Leg rest down button: Adjust the leg rest downward.
6. Leg rest up button: Adjust the leg rest upward.
7. Linkage sitting key: Adjust the linkage sitting angle.
8. Linkage lying key: Adjust the linkage lying angle.
9. Wireless phone charger: wireless charging of mobile phone.
10. 3D intensity knob: adjust the massage intensity of the 3D robot.
11. Switch: Hold it down for 2 seconds to turn on or off the massage chair.

Usage and Controls

Button	Description
	Power button: Short press this button to pause the operation; if it is hold down for 3 seconds, power will be ON/OFF. If the pause time during massage exceeds 20 minutes, all the massage functions will be automatically turned off.
	3D intensity: Adjust the massage intensity of 3D manipulator (counterclockwise indicates "-", while clockwise indicates "+"). The intensity range is Level 1-5.
	Linkage sitting key: By holding down this key, the backrest will rise slowly and the leg rest will move downward slowly; by releasing it, the movement of the backrest and the leg rest will be stopped.
	Linkage lying key: By holding down this key, the backrest will move downward slowly and the leg rest will rise slowly; by releasing it, the movement of the backrest and the leg rest will be stopped.
	Leg rest up button: Hold down the button to make the leg rest rise slowly. Release it to stop such action.
	Leg rest down button: Hold down the button to make the leg rest move downward slowly. Release it to stop such action.
	Heat treatment key: Click the key to enable or disable the heat treatment function.
	Voice Control Awake Key: Short press to enable voice control function, Long press 3 seconds to turn on or off voice control function. If no valid voice entry is recognized within 6 seconds, the voice function will be turned off automatically (This button is only effective when the voice switch is turned on).
	Automatic mode key: Press it to switch among those automatic massage functions.

Usage and Controls

VOICE CONTROL MODE | available in English only

Press the  button on the armrest for at least 3 seconds to switch the voice control function on or off. If the massage chair is switched on or in standby mode, you can activate voice control by saying "Hi Alice" or "Hey Alice". Once the function is activated, the massage chair will respond by saying "I am here". If an appropriate voice command isn't made within six seconds, the voice control function will switch off automatically and need to be reactivated.

VOICE CONTROL ENTRY

"Massage on"

"Massage close"

"Comfort massage"

"Relax massage"

"Full body massage"

"Neck massage"

"Back and waist massage"

"Stretch massage"

"Open the air pressure"

"Close the air pressure"

"Up the seat position"

"Down the seat position"

"Change the other mode"

"Go little down"

"Go little up"

ANSWER ENTRY

"Ok, massage on"

"Ok, massage close"

"Ok, comfort massage"

"Ok, relax massage"

"Ok, full body massage"

"Ok, neck and shoulder massage"

"Ok, back and waist massage"

"Ok, stretch massage"

"Ok, open the air pressure"

"Ok, close the air pressure"

"Ok, up the seat position"

"Ok, down the seat position"

"Ok, change the other mode"

"Ok, go little down"

"Ok, go little up"

NOTE

When waking up the voice control function, please use English, the speech rate is moderate, voice commands should follow the voice entry.

Specials



ROLLING

Pleasant alternation between relaxation and releasing the muscles – also perfectly suited for a final massage, for relaxation and recovery of the muscles.



KNEADING

Skin and muscles are either clasped and kneaded between the thumb and the index finger or with both hands. This massage technique is used in particular to ease tension.



AIR COMPRESSION

Rising and receding airbags have a pumping motion which produces natural muscle reflexes. This is particularly beneficial in the calf and foot area.



CARBON HEATING

Deeply penetrating Carbon infrared heat, blood vessels expand, the blood flow increases and the muscle tone is reduced. In addition, it carries out a highly beneficial effect on nerve cells, which are responsible for reporting pain to the brain.



KNEAD & TAP (DUAL ACTION)

The techniques of kneading and tapping are combined in order to relieve tension and stimulate blood circulation at the same time.



TAPPING

Short, tapping movements are performed with the edge of the hand, the palm or the fist. This promotes blood circulation in the skin and softens tense muscles. If tapping is performed at lung height, this can improve the release of mucus in the lung.



SOLE ROLLER

The foot massage stimulates the nerve endings and certain organs of the body, which also relaxes the muscles.



L-SHAPE

You can expect a profound full body massage from the neck down to the buttocks.

Specials



S-LINE

With this automatic program the massage heads are working very close to your body, they massage the whole back down to your buttocks. The S-shaped mechanic is constructed after the natural anatomy of the spine.



ZERO SPACE

For the lying-position the massage chair moves forward and therefore requires very little distance to the wall behind. Space saving and comfortable!



ZERO GRAVITY

You put yourself in the position of an astronaut – that "weightless feeling".



AUTOMATIC

22 specifically developed automatic programmes for the whole body, which offer a big range of different massage techniques. Additionally you can also turn on the heating function, if you'd like.



MEMORY

Using the intelligent memory function the massage chair remembers your favourite massage exactly and begins immediately without a scan.



BACK AREA

An individual applicable to any size massage area.



ARTHROSE TRACTION

Arthrosis Traction consists of gentle stretching pressure. It has a stimulating effect on the cartilages, which enhances the transport of bodily fluids, nutrients absorption and can alleviate symptoms of arthrosis.



ADJUSTABLE FOOTREST

The footrest can be extended, this way it is adaptable to different body sizes.

Specials



ADJUSTABLE PILLOW

If necessary, the double cushion can be placed to reduce the neck and shoulder massage intensity.



RECLINING POSITION

The adjustability of the backrest and footrest contributes to personal well-being of the body position.



BRAINTRONICS®

Braintronics® technology synchronises your brainwaves through audio stimulation. Combined with a specially developed massage programme your stress-ridden body will be able to relax. No matter whether you'd like to relax, dream or learn – anything's possible.

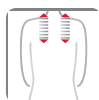

ADJUST SHOULDER

The massage heads can be moved upward or downward to a suitable position in the shoulder area.



AIR INTENSITY

Adjustable airbag massage intensity.



AIR AREA

Whole body airbag massage. Different areas are individually selectable.



BACK STRETCH ROLLING

Targeted stretch massages activate the body and have an invigorating effect on the whole body.



3D MASSAGE

In this new technique, the massage robot not only moves upwards and downwards, but also forwards and backwards.

Specials



SHIATSU

Shiatsu (finger press) is a form of body therapy originating in Japan. The massage technique consists of soft, rhythmic, far-reaching stretches and rotations. The aim of Shiatsu is to simulate individual parts of the body and to mobilise the muscles.



SHOULDER GRASP

Targeted kneading massage in the shoulder/neck area – ideal for easing tension and pain in this area.



WAIST STRETCH

Airbags in the lower area of the back ensure gentle stretching of the pelvis. Effectively counteracts tensions.



SPOT

The massage heads can massage a particular spot.



SPEED

Massage speed is adjustable.



WIDTH

The distance between the both massage heads can be set (narrow, medium and wide).



MUSIC

Further relaxation and fun with the music function.



BLUETOOTH

Wireless data transmission.



ACUPRESSURE POINTS

Key acupressure points are massaged.

Specials



REFLEXOLOGY

Reflexology regenerates foot muscles and has a harmonizing effect on almost all organs inside your body.



HUMAN HANDS FEELING

Specially designed massage heads imitate the hand motion of a professional masseur. The maximum stretch space is 6,5 cm, and the maximum stretch angle is 41 degrees, so the mechanical hands can do effective massage to human cervical vertebra thoracic vertebra and lumbar vertebra.



QUICK START

With one touch the quick start buttons in your armrest allow you to control the most important functions.



DUAL SENSOR BODY SCAN

The massage chair performs a body scan to capture the main areas of the neck and back to ensure optimal pressure throughout the massage. The scan technology detects the height of your shoulders, that can be modified after the scan, if required.



VOICE CONTROL

Use the voice control to activate selected functions.



WIRELESS CHARGER

Wireless charging function for NFC-smartphones.



MAGNETIC THERAPY FUNCTION

Air bags for the left and right palm have a unique massage function using magnetic field therapy.



CALF KNEADING

Kneading and pressure massage functions in the leg airbags ensure that any tension of the leg muscles that may be caused by long periods of standing are relieved.

EU-Declaration of conformity

Complies with European Regulatory Standards EMC 2014/30/EU, LVD 2014/35/EU and RohS regulations.

Warranty conditions

The retailer guarantees a statutory period of warranty for the product described on the reverse. Warranty is valid from the date of purchase. The purchase date must be documented with proof of purchase. The retailer will repair or replace defective products registered within Germany free of charge. This does not include parts subject to wear such as fabric covers. This requires the defect device to be sent in with proof of purchase before expiration of the warranty period.

The warranty is void if a defect occurred e.g. due to outside influences or as a result of a repair or modification not performed by the manufacturer or an authorised dealer. The retailer warranty is limited to product repair or replacement. Under this warranty, the manufacturer or the retailer shall have no further liability and is not responsible for damages due to failure to observe the instructions for use and/or improper use of the product.

If after examining the product, the manufacturer determines the warranty claim is not for a defect covered by the warranty or that the warranty period has expired, the customer is responsible for the costs of the inspection and repair.

Legal notice: None of the contents have any healing value. The diagnosis of and therapy for illnesses and other physical disorders requires treatment by a doctor, alternative practitioner or therapist. The statements are exclusively informative and should not be used as a replacement for medical treatment. Every user is instructed to carefully assess their situation and, where necessary, consult a doctor to determine whether using the product is encouraged in their own unique case. Every use or therapy is undertaken at the user's own risk. We dissociate ourselves from any healing properties or commitments.

Casada International GmbH
Obermeiers Feld 3
33104 Paderborn, Germany
info@casada.com
www.casada.com

Copyright Images and text are subject to the copyright of CASADA International GmbH and may not be used without express consent.
Copyright © 2024 CASADA International GmbH.
All rights reserved

